

Type examination certificate P-4110/19

- Applicant:** Blasi GmbH
Carl-Benz-Straße 5-15
77972 Mahlberg
- Production site:** Blasi GmbH
Carl-Benz-Straße 5-15
77972 Mahlberg
- Design:** three-wing revolving door with rigid and hinged wings with an external rotor drive
Diameter 4800mm Headroom 2200mm Weight of wings 1959kg (corresponds to J = 4380kgm²)
- Type:** **K32**
three-wing revolving door with rigid and hinged wings with an external rotor drive
K32-FE
three-wing revolving door with hinged wings for use in escape and emergency routes with an external rotor drive
K42
four-wing revolving door with rigid and hinged wings with an external rotor drive

Permissible design:

- **K32** as an external rotor drive

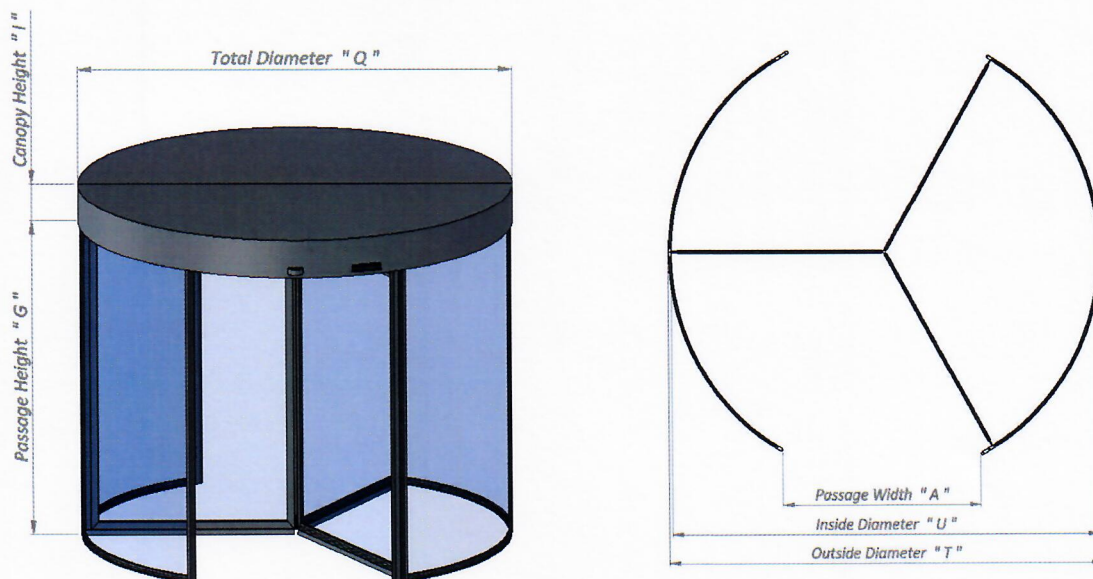

U = Inside diameter	max. 3600 - 6500mm	
A = Passage width (between drum walls)	Passage width A in mm = "Q" * 0.5 - 130	
Q = Outside diameter (canopy)	Outside diameter = U + 58mm	
I = Canopy height	≥ 350mm = <Ø 5000mm	≥ 550mm > Ø 5000mm
	plus air curtain	
G = Passage height	min. 2000mm – max. 3000mm	
LH = Light height	min. G + I + 50mm	
LB = Light width	min. Q + 100mm	

- **K42** as an external rotor drive

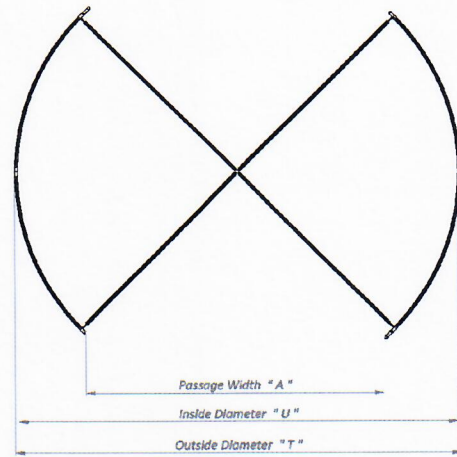
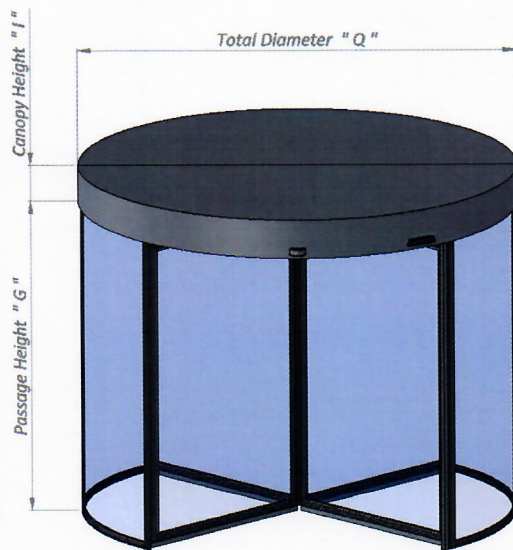

U = Inside diameter	max. 3600 - 6000mm	
A = Passage width (between drum walls)	Passage width A in mm = "Q" * 0.7 - 120	
Q = Outside diameter (canopy)	Outside diameter = U + 58mm	
I = Canopy height	≥ 350mm = <Ø 5000mm	≥ 550mm > Ø 5000mm
	plus air curtain	
G = Passage height	min. 2000mm – max. 3000mm	
LH = Light height	min. G + I + 50mm	
LB = Light width	min. Q + 100mm	

Technical details:

Nominal voltage:	110-240 V AC, 50/60 Hz
Rated power:	1100W
Protection system:	IP20
Protection class:	I
Temperature range:	-15°C - +50°C
Humidity range:	up to 85% rel. humidity
Control voltage:	24V DC
Control type:	2 x KST200 with 3 x drive AST200
Motor voltage:	48V DC
Motor type:	DC motor
Max. turnstile weight:	2000kg

Glazing:

- All curved glass is 10mm laminated safety glass, optionally 8mm and 12mm possible
- All flat glass is 10mm single sheet safety glass or 10mm laminated safety glass, optionally 8mm and 12mm possible
- Optionally 12mm panel filling possible
- Optionally P4A / P5A glass at 9.5mm to 14.5mm may be used

Protection:

- Drum edge
 - contact profile, Gelbau, type: 3100.0310I or 3100.4053
 - presence sensor, Bircher, type: Prime Scan A, Bea, type FlatScan Rev
- Rotor, horizontal door leaf edge
 - contact profile, Gelbau, type: 3100.1610 (at bottom)
 - presence sensor, Bircher, type: UniScan, Bea, type FlatScan SW, Bea, type LZR P110
- Rotor, vertical door leaf edge
 - contact profile, Gelbau, type: 310.1610

Design of rotor:

- pendulum wing mechanically locked to manually open
- rigid wing

Permissible options:

- Automatic activation via radar sensors (fully automatic)
- Manual activation via push bar (semi-automatic)
- Sensor for inside and outside activation via potential-free contacts
- Electromechanical, bistable locking unit in drive
- Roof tray with waterspout
- Various floors and matting
- Night locking
- Air curtain
- UPS to temporarily ensure function during a power failure
- Interior lighting
- BDE-V key switch
- Use of the leaf locking HST200 with standard revolving doors as well as revolving doors for use in escape and rescue routes,
- Use of BreakOut side screens in three-wing revolving doors of type K32 according to the table, and in revolving doors of type K32-FE for use in escape and emergency routes.

Agreed test regulations:

1. DIN EN 16005: 2013-01
Power operated pedestrian doorsets – safety in use
2. DIN EN 60335-1: 2012-10
Household and similar electrical appliances - safety
Part 1: General requirements
3. DIN EN 60335-2-103: 2016-05
Household and similar electrical appliances - safety
Part 2-103: Particular requirements for drives for gates, doors and windows
4. DIN EN ISO 13849: 2008-12
Functional safety of machines – safety-related parts of control systems

as well as other applicable standards, regulations and guidelines listed in the above test regulations.

Requirements:

1. Before the unit is installed and put into operation a property risk assessment is to be carried out taking the local conditions into account. The unit is to be fitted with the requisite sensors and safeguards according to the result of the risk assessment.

2. The control section of the revolving doors of types K32, K32-FE and K42 is only suitable for environment spaces and must be labelled accordingly. In deviant circumstances proper seals and drainage are to be fitted.
3. Installation and commissioning is required by the manufacturer or by an authorised company.
4. Rotor wings and side panel wings of transparent materials are to be labelled in clearly recognisable fashion.
5. Every automatic revolving door has to be fitted with an all-pole-breaking main switch that is protected against erroneous or unauthorised use. Connecting the drive via plug-and-socket devices according to accepted rules of engineering is permitted.
6. Automatic revolving doors must be additionally equipped with an EMERGENCY-stop switch within close proximity. The emergency-stop switch should be mounted between 0.85m and 1.20m above the floor.
An EMERGENCY-stop switch on the outside is not necessary in accordance to DIN EN 16005.
7. Buttons for people with disabilities to reduce the nominal rotation speed of the rotor may be set up on the two access sides of the revolving door at a height of up to 0.85m.
8. Before initial operation, the revolving door requires inspection by a technical expert with documentation of testing results.
9. The technical documentation as listed below has to be handed over to the user (owner) with each revolving door:
 - operating instructions
 - test book with details of maintenance and maintenance conditions
 - a copy of this type examination certificate, test mark P-4110/19.

Notes:

1. The type examination certificate is only valid in conjunction with test report P-4110/19.
2. The design does not meet any requirements for reasons of fire protection (fire resistance, smoke control).
3. Further requirements of the competent building control authorities pursuant to the state building code applying to the installation point remain unaffected by this certificate.
4. Burglary resistance tests and EMC were not included in the type examination.
5. The type examination certificate is valid until 2023-12-31. If the technical rule changes significantly, a new test may be necessary.

Zella-Mehlis, 2019-05-29

Technischer Überwachungsverein Thüringen e.V.
Test centre for construction products

Dipl.-Ing. (FH) Reichelt
Head of test centre

